



Instruction Sheet

QHMZ1P-1 Switching Relay

EFFECTIVE: May 20, 2015

Features:

External Indicator Lights
 Universal Replaceability
 Snap-in PC Board
 Simplified Wiring
 Sealed Relays
 Fuse Protected Outputs
 100% Factory Tested
 Contractor Friendly PC Board Layout
 Universal Thermostat Compatibility
 UL Approved

Operation:

Connect a thermostat to the "T T" terminals on the switching relay. When the thermostat calls for heat, the relay is energized and power is given to the circulator.

Power Input:

Connect 120 volt ac power to terminals N and H.

Jumper Placement:

The jumper is factory installed between terminals H and 3 to switch power on terminals 4 n/o and 4 n/c.

Terminal Description:

T & T Thermostat Connection
 COM Common side of transformer, to power some setback thermostats
 N Neutral wire of power input
 H Hot wire of power input
 3 Common terminal for 4 n/o and 4 n/c
 4 n/o Normally open terminal
 4 n/c Normally closed terminal
 6 n/c Normally closed terminal
 6 n/o Normally open terminal
 5 Common terminal for 6 n/o and 6 n/c

Specifications:

PRODUCT NUMBER	NUMBER OF ZONES	INPUT VOLTAGE	MAXIMUM COMBINED LOAD	TYPE 1 ENCLOSURE		
				WIDTH	HEIGHT	DEPTH
QHMZ1P-1	1	120/60/1 VAC	12 amps	4 ⁷ / ₈ "	6 ⁵ / ₈ "	2 ³ / ₈ "

All circulator relay connections, including ZC/ZR, are rated 1/3 hp (6 FLA, 36 LRA) at 120 VAC. The thermostat connection supplies a 24 VAC class 2 output.

Wiring Diagram for Thermostats that require an external transformer

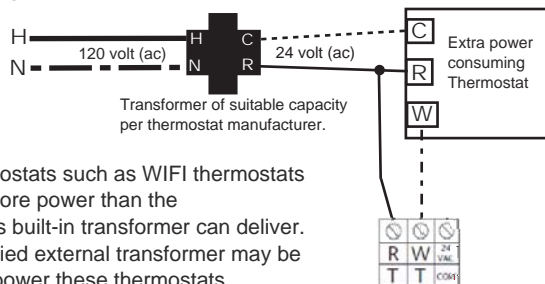

Typical Wiring:

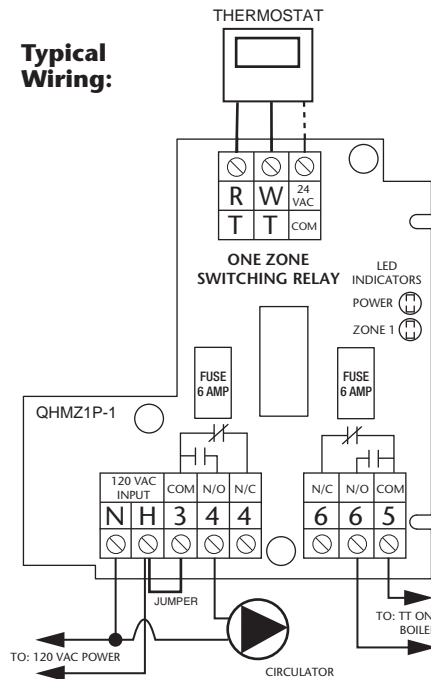

Alternative Wiring:

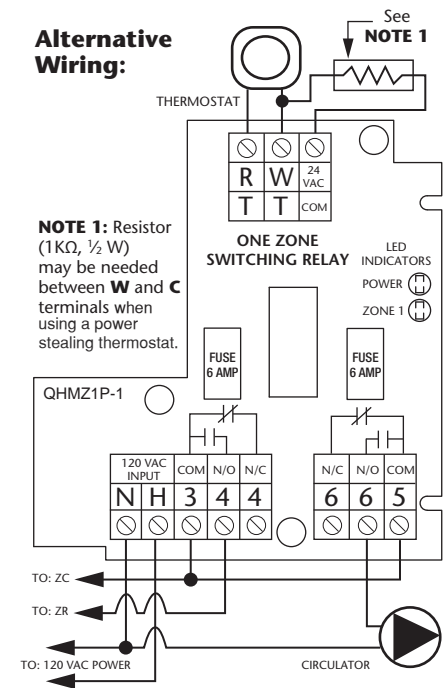

NOTE 2: When using Alternative Wiring diagram, the boiler operating control's ZC terminal will see the load of the circulator(s).

WARNING: When using Alternative Wiring diagram, wiring instructions must be followed so power originates from the boiler aquastat. Failure to follow these wiring instructions may result in a secondary source of power being connected to the boiler that may activate it under certain circumstances, causing injury or death.

Troubleshooting:

- Problem:** Digital thermostats do not work correctly when connected to a switching relay.
- Solution:** Some thermostats are a "Power Stealing" type which means they are powered by the switching relay with just 2 wires (R & W). A resistor may be needed in order to have the thermostat work properly. This resistor should be placed between the W & C (common) terminals of the switching relay. If the thermostat manufacturer does not supply a resistor, a 1000 ohm 1/2 watt resistor has proven to work with most models and is readily available at electronic supply outlets (e.g. Radio Shack). If the thermostat is battery powered, then check that the batteries are fresh and installed correctly.
- Problem:** No heat in a zone or room of building.
- Solution:** LED diagnostic lights will help find a component that is not working properly. The green LED should always be on, indicating that power is connected and the solid-state fuse is good. When there is a call for heat, the red LED will come on indicating power to the zone circulator. This indicates the thermostat is working correctly. If the red LED does not come on, then check the thermostat and thermostat wiring for errors.

WARNING: Wiring connections must be made in accordance with all applicable electrical codes. Use copper wire only. 120 VAC wiring must have a minimum temperature rating of 75°C. Failure to follow this instruction can result in personal injury or death and/or property damage. 12-18 gauge wire recommended for 120 VAC connections, 14-22 gauge wire for thermostat connections and for 24 VAC source connections.

This device complies with part 15 of the FCC Rules. Operation is subject to the following two conditions: (1) This device may not cause harmful interference, and (2) this device must accept any interference received, including interference that may cause undesired operation. (Replacement Switching Relay fuses Manufacturer: Littlefuse, Part Number: 229006)

ZURN PEX PLUMBING AND RADIANT HEATING SYSTEMS 1801 PITTSBURGH AVENUE, ERIE, PA, U.S.A. 16502
 PHONE: 800/872-7277 FAX: 800/209-2148 WEBSITE: www.zurn.com

IN CANADA: ZURN INDUSTRIES LIMITED 3544 NASHUA DRIVE, MISSISSAUGA, ONTARIO L4V 1L2
 PHONE: 905/405-8272 FAX: 905/405-1292